



It's what's on the inside that counts!

Wick Fitting Instructions

LOOKING ON THE INSIDE OF THE SWINGING ARM

(THESE DIMENSIONS ONLY APPLY WHEN RIDER IS SAT ON BIKE)

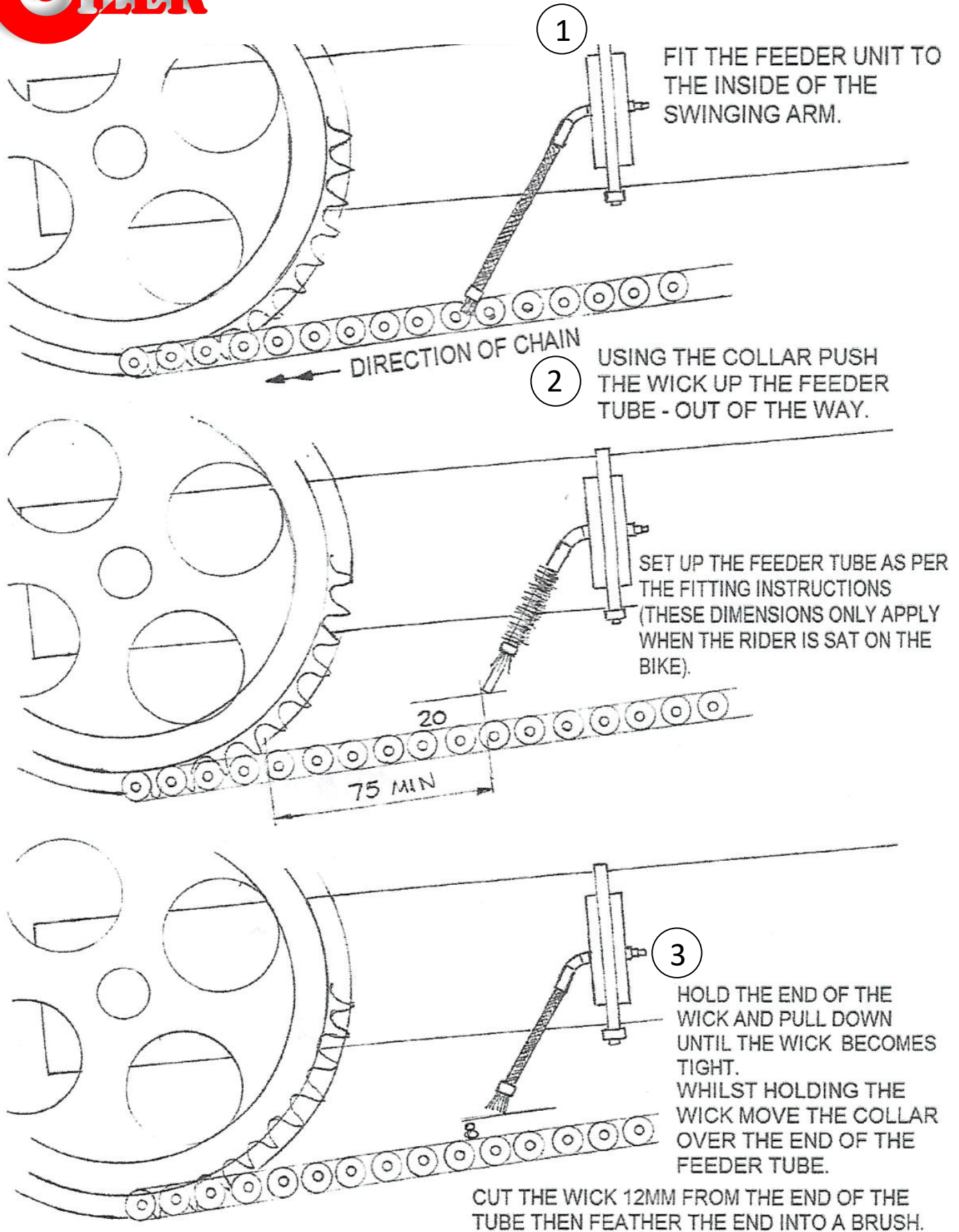



It's what's on the inside that counts!

PDOiler MK3A

FITTING & OPERATING INSTRUCTIONS

1. Select anywhere* on bike to fit oiler container with filler cap uppermost, and the vent pipe with outlet also at the highest position. The container may be laid on its side but not less than 15 degrees from the horizontal. No need to secure at this stage. *(because it will pump uphill!).

2. Fit the feeder tube assembly on the inside of the swinging arm, position the tube end so that it is more than 75mm before the chain meets the rear sprocket and 20mm above the centre of the rollers (cut tube if necessary), secure using cable tie (supplied) - when tightening the cable tie make sure the rubber support is flattened. If you have a tapered swinging arm – you may need to use the cable tie mounts to stop it slipping.

WE ADVISE YOU SET THE FEEDER ASSY. AS PER OUR INTRUCTIONS.

3. Route supply tube through frame, try to ensure the tube passes close to the swinging arm pivot (this will minimise the movement of the tube), position the self-adhesive clips where necessary (clean surface before fitting), then fit tube into clips and on to meet the oiler container nipple. **DO NOT FIT TUBE TO THE NIPPLE** you need to prime the supply tube (green) with oil until it comes out on to the chain using the syringe and adaptor provided or an oil can. Fit tube to nipple. Secure the container (using the cushion pad and cable ties.) supplied.

4. Connect electrical lead (black wire) to negative terminal of battery or wire connected to negative terminal of battery, the other (red wire, fitted with in line fuse) to wire operated by the ignition switch or wire connected to the rear light (this will need a some electrical knowledge, if unsure, gain professional help). Select suitable place to fit the timer, plug connector of timer to the connector of the oiler unit then the other connector to the connector of the In-Line fuse. Switch ignition or lights on, you can check operation, the green light will come on and stay on, the red light will come on when activated, this indicates when the oiler is pumping, the off time can be adjusted using the control knob. Note: the timer programme will always begin with the off time (about 30-130sec.) depending upon the setting, followed by the on time and so on. **Do not modify the pump cable, as the cable is sealed at the connector end.**

5. Filling Instructions

(a) Remove the Dip tube.

(b) Inject oil using syringe (supplied) or oil can (we recommend our own chain oil) or Gear Oil EP80/90) but any suitable oil will do, into the container until the upper marker of Dip tube, replace the Dip tube, regularly check oil, to do this, place finger over top of tube and withdrawal. Replenish when the oil gets close to the lower (Red) mark. **DO NOT LET THE OIL RUN DRY.**

(c) Set timer knob to 9 on scale. Upon activation of ignition switch or lights, oil will appear in the supply tube in pulses of approx. 20secs. Until oil drips out of the end onto the chain. This may take 50 minutes or so or you can prime the system first by filling the supply tube with oil (see 3. above) – using the syringe or an oil can, etc,

(d) Set control knob to suit rider requirements.

CAUTION

During operation, oil may find its way onto the rear wheel and tyre, it is advisable to remove this without delay.

Technical information: Voltage: 12v Current: 0.6A Power consumption: 7.2w (when activated.)

Fuse Type: 1A (F) (Quick Blow) 20mm x 5mm

E Mail:bristo34@yahoo.co.uk E. & O. E. June 2021



It's what's on the inside that counts!

PDOiler Automatic Chain Oiler

'PD' stands for POSITIVE DISPLACEMENT. The unit will deliver a metered amount of oil (when red light glows).

The delivery of the oil upon activation of the timer unit is not affected by temperature changes and will continue to work in extreme conditions -5c to +50c.

The delivery of oil can be adjusted between 13secs to approx. 110secs irrespective of temperature or oil grade.

The container can be fitted anywhere on the bike because being a pump system it will also pump uphill! (max.1m)

We recommend our own chain oil or Gear Oil EP80/90, but you can use any suitable lubricating oil in an emergency.

Easy to set up (but some electrical knowledge necessary).

Electrically operated 12v system. Automatically operated by ignition switch.

Uses only 7 watts in power and this only happens when the timer is activated.

A well oiled chain will increase its life and also raise the efficiency and performance of the bike eg. lower fuel consumption , higher top speed, quieter, etc.

The cylinder size is 35mm diameter x 140mm long and will usually fit on any part of the bike. Bikers usually fit the container under the rear side fairing with the filling spout accessible.

The container holds 100cc net. of oil.

We make the 'PDOiler' as simple as possible to cut the cost of manufacture. Spare parts are available for most components.

Supplied with fitting instructions.

June 2021



It's what's on the inside that counts!

MK3 Assembly Container

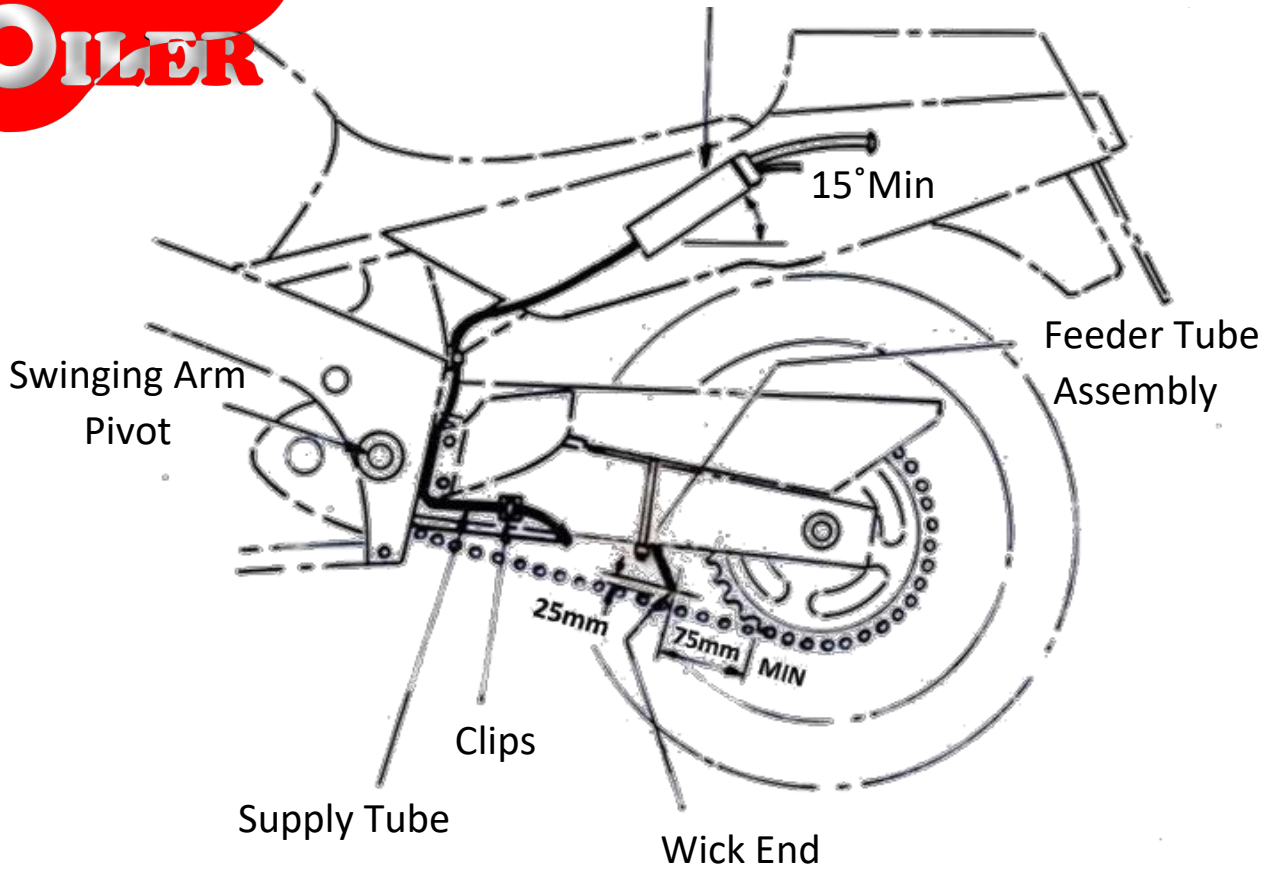

Cable Ties (Hide Under Moveable Caps)

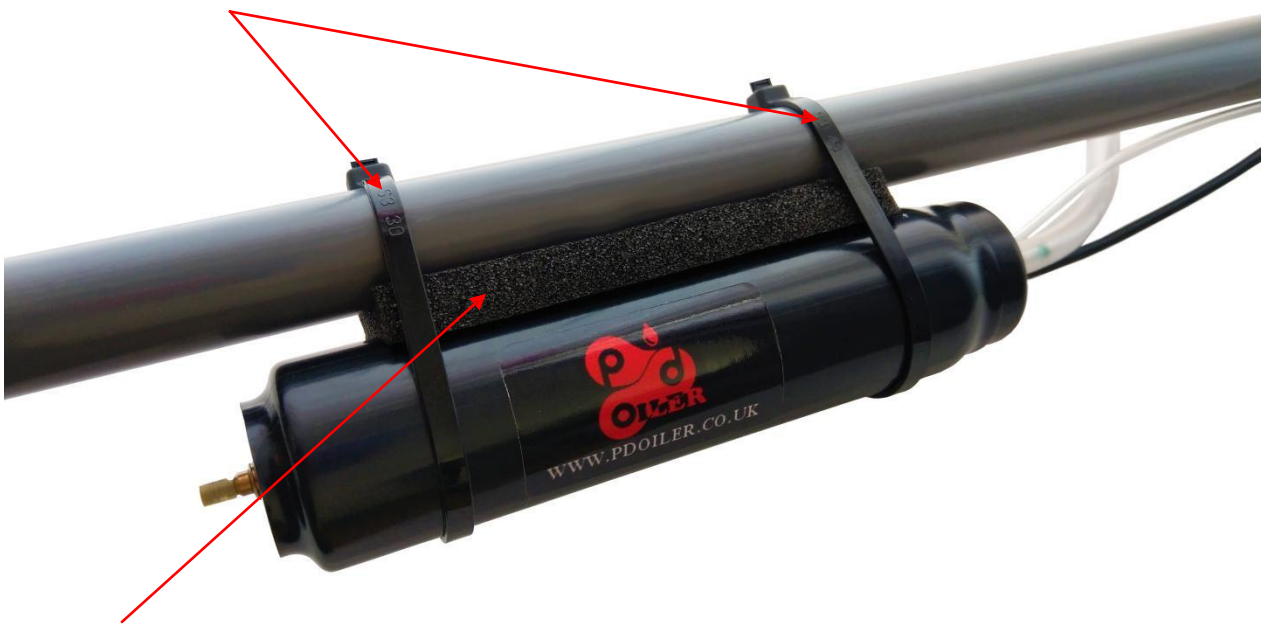

Cushion Pad (MUST BE USED!)