



*It's what's on the inside that counts!*

## **PDOiler Mini**

### **FITTING & OPERATING INSTRUCTIONS**

1. Select anywhere\* on bike to fit the PDOiler pump the reservoir and the timer. The pump may be laid on its side but not less than 15 degrees from the horizontal. No need to secure at this stage. \*(because it will pump uphill!). The Reservoir may be fitted in the upright position or can be laid down, ensure the Vent pipe is uppermost, you may cut the pipe to not less than 2 cm. Route the Filling tube to a position where you will be able to reach for the filling operation. Route the supply tube on to the pump; do not connect to the pump at this stage.

2. Fit the feeder tube assembly on the inside of the swinging arm, position the tube end so that it is more than 75mm before the chain meets the rear sprocket and 20mm above the centre of the rollers (cut tube if necessary), secure using cable tie (supplied) - when tightening the cable tie make sure the rubber support is flattened. If you have a tapered swinging arm – you may need to use the cable tie mounts to stop it slipping. **WE ADVISE YOU SET THE FEEDER ASSY. AS PER OUR INTRUCTIONS.**

3. Route supply tube (green) through the frame, try to ensure the tube passes close to the swinging arm pivot (this will minimise the movement of the tube), position the self-adhesive clips where necessary (clean surface before fitting), then fit tube into clips and on to meet the pump nipple. **DO NOT FIT TUBE TO THE NIPPLE you need to prime the supply (green) tube with oil until it comes out on to the chain using the syringe provided or an oil can.** Fit tube to outlet nipple. Secure the pump (using the cushion pad and cable ties.) supplied.

4. Connect electrical lead (black wire) to negative terminal of battery or wire connected to negative terminal of battery, the other (red wire, fitted with in line fuse) to wire operated by the ignition switch or wire connected to the rear light (this will need a some electrical knowledge, if unsure, gain professional help). Select suitable place to fit the timer, plug connector of timer to the connector of the oiler unit then the other connector to the connector of the In-Line fuse. Switch ignition or lights on, You can check operation, the green light will come on and stay on, the red light will come on when activated, this indicates when the oiler is pumping, the off time can be adjusted using the control knob. Note: the timer programme will always begin with the off time (about 30-130sec.) depending upon the setting, followed by the on time and so on. **Do not modify the pump cable, as the cable is sealed at the connector end.**

#### 5. Priming

No need to prime the pump as it is already filled with oil when it leaves the manufacturers.

Pump oil into the tube from the reservoir until it comes out into the Reservoir chamber, then fit to inlet nipple of the pump.

In the event that the pump needs priming, you will need to remove the pump and fill the syringe with oil, connect to inlet nipple of the pump holding the pump vertical with outlet uppermost, pump the syringe enough for the oil/air to come out of the outlet until you get a continuous flow of oil (no air) remove the syringe and fit the pump back on bike.

#### 6. Filling Instructions

(a) Inject oil (we recommend chain oil supplied by us or gear oil EP80/90) but any suitable oil will do, into the reservoir (using syringe (supplied) or oil can). Regularly check oil. **DO NOT RUN WITH NO OIL.**

(b) Set timer knob to 9 on scale. Upon activation of ignition switch, oil will appear in the supply tube in pulses of approx. 20secs. Until oil drips out of the end onto the chain.

(c) Set control knob to suit rider requirements.

#### CAUTION

**During operation, oil may find its way onto the rear wheel and tyre, it is advisable to remove this without delay.**

Technical information: Voltage: 12v Current: 0.6A Power consumption: 7.2w (when activated.)

Fuse Type: 1A (F) (Quick Blow) 20mm x 5mm

E Mail: [bristo34@yahoo.co.uk](mailto:bristo34@yahoo.co.uk) Last E. & O. E June 2021



*It's what's on the inside that counts!*

## **PDOiler Mini Reservoir Fitment Orientation**

These diagrams will give you an idea of the correct fitting position/orientation of the PDOiler Mini Reservoir

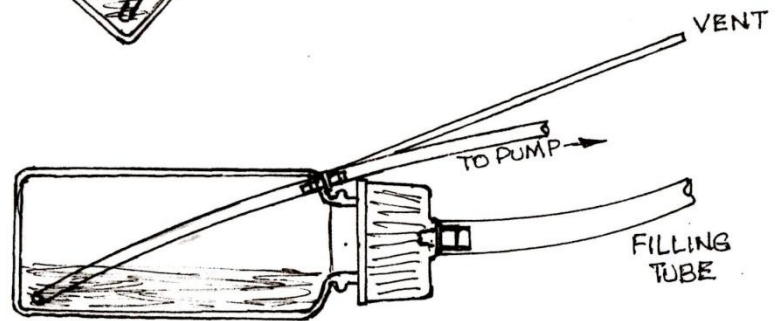
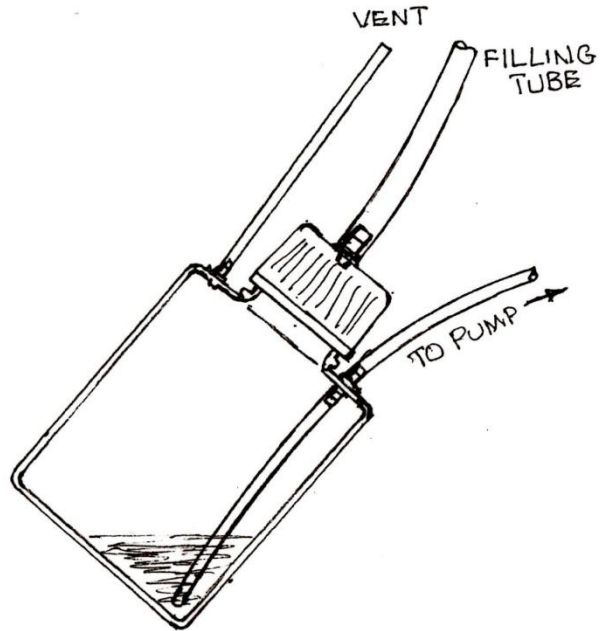
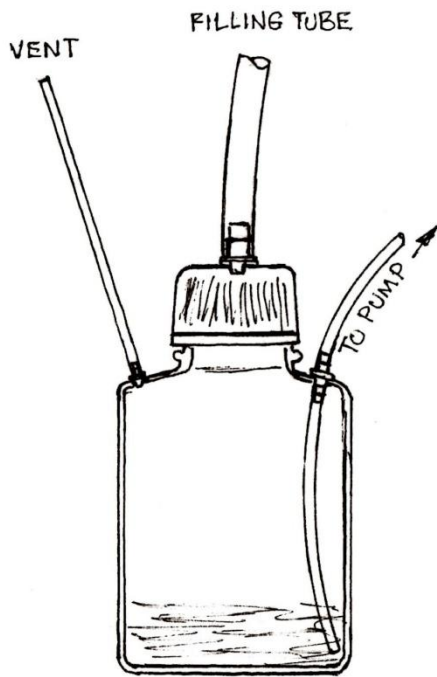



*It's what's on the inside that counts!*

## Wick Fitting Instructions

LOOKING ON THE INSIDE OF THE SWINGING ARM

**(THESE DIMENSIONS ONLY APPLY WHEN RIDER IS SAT ON BIKE)**

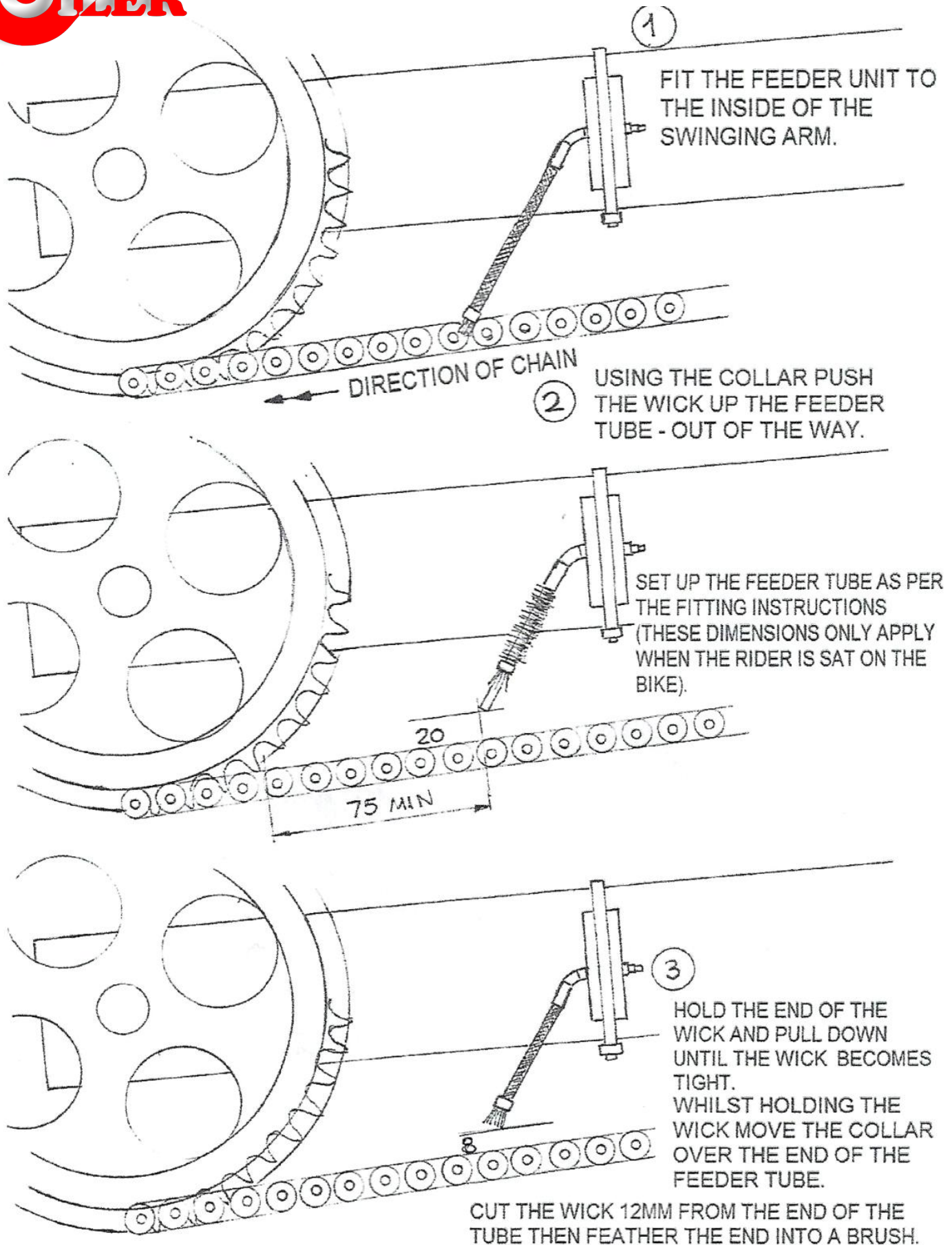



*It's what's on the inside that counts!*

